

**Articolo 38 – Organigramma generale delle funzioni in staff alla Direzione Aziendale**

A) In staff al Direttore Generale

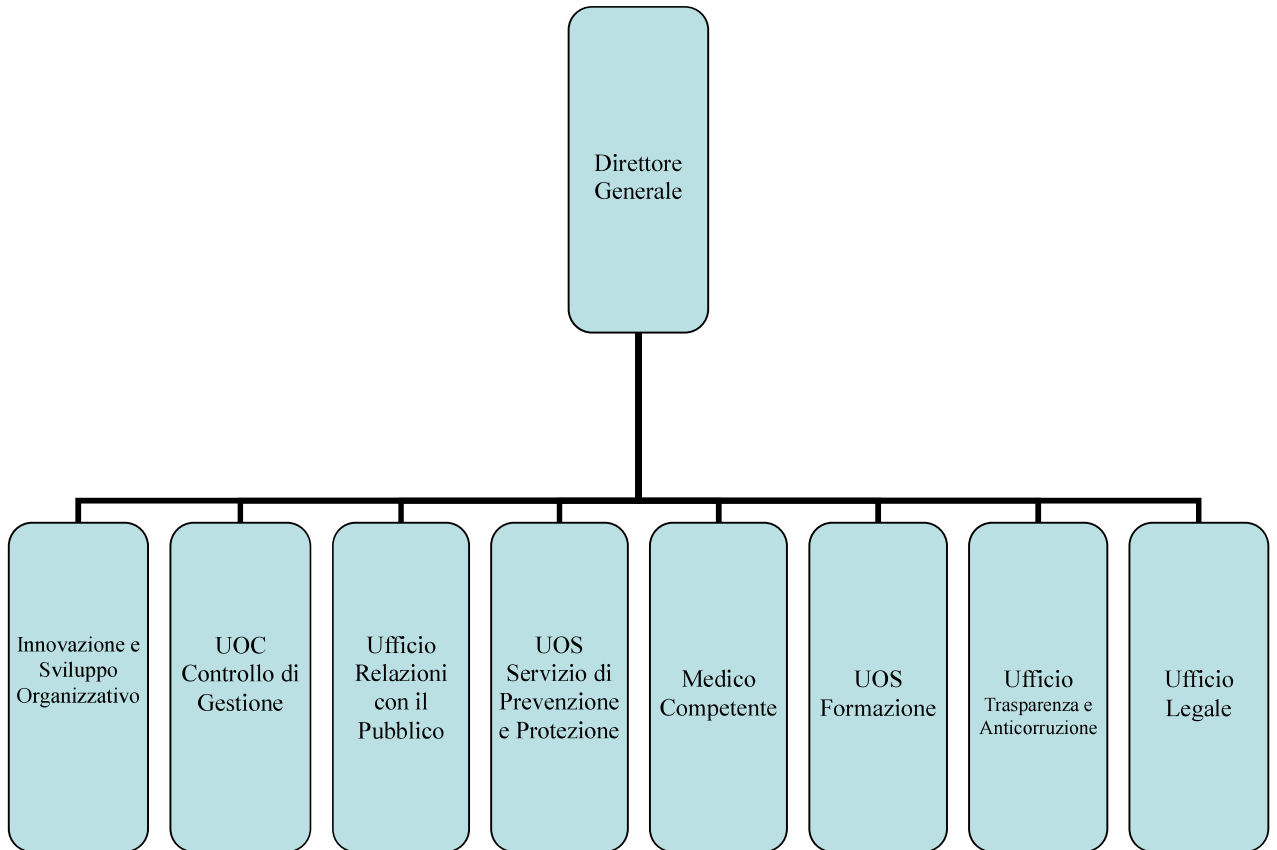

B) In staff al Direttore Sanitario

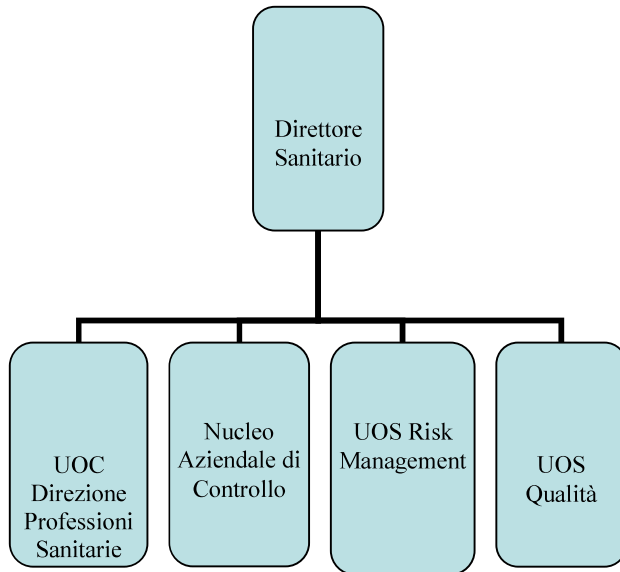

C) In staff al Direttore Amministrativo

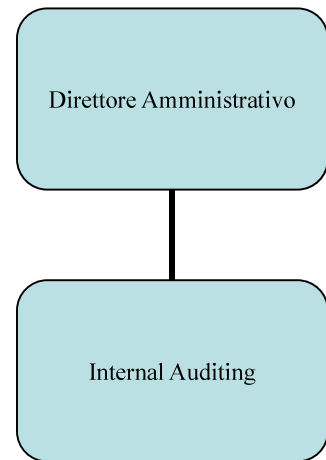

D) In staff al Direttore dei Servizi Socio-Sanitari

